



DESIGN: RANDY BORDEN

Shown in Satin Aluminum with solid shade



350

LUMINOUS SHADE

Design
Sustainability
Value



print this page



email this page to a colleague



installation instructions



interactive submittal drawing

COMPANION



818

FEATURES

- Simple, clean design.
- Shielded lamp, but is optically efficient.
- Tool-free relamping.
- Available with solid or luminous shade.

MATERIALS

- Solid brass or aluminum metal work, hand finished.
- Luminous shade and cone are white acrylic with a matte finish.
- White SJ cord standard. Available in black or with metal stem.

FINISHES

- SAL** Satin Aluminum
- SB** Satin Brass
- AB** Antique Brass
- CCP** Custom Color Painted finish

Standard metal finishes are hand satined and either waxed or sealed with a water-based clear coat. Other metal finishes are available. Contact factory.

LAMPING

1-CF26W or 32W or 42WTTT, Gx24q base.
Lamps not included.

BALLAST

Integral canopy-mounted electronic HPF, 120V/277V.
See "GENERAL INFO" for more detail.

ECO INFO

METALS: Aluminum and brass with the highest available recycled content for lower embodied energy. Both metals are valuable and recyclable at the end of the products useful life. For more information see "GENERAL INFO"

FINISHING: Aluminum and Antique Brass finishes are sealed with a hand-applied bees wax. No paint or lacquer is used in order to avoid pollution associated with the manufacture and application of these substances. Satin Brass is clear-coated with a very low VOC water-based coating. Paint finishes are low VOC and oven cured.

ENERGY: Designed exclusively for compact fluorescent lamps using HPF electronic ballasts.





Shown with luminous shade

350

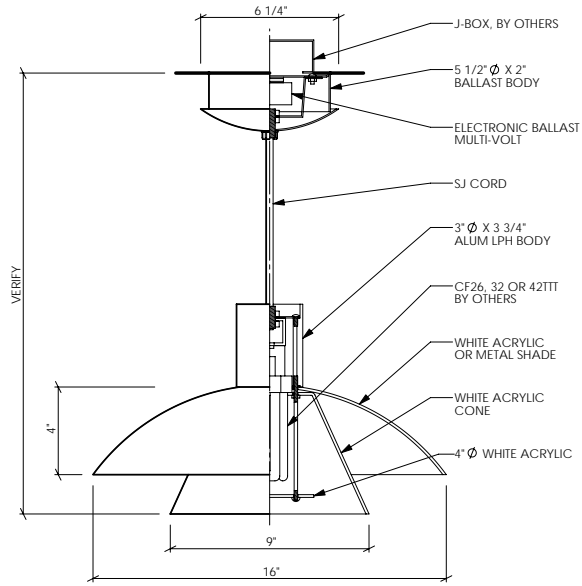

OPTIONS

FAUX: Hand applied faux finish available. Specify **FAUX**. (FAUX is for upper shade only.)

STEM: Available with a metal stem & swivel canopy, specify **STEM**.

UPPER SHADE: Choice of luminous white acrylic or opaque metal shade. Specify **LS** or **MS**.

DIMMING: Our standard dimming electronic ballast has range of 100-15%, 120 volt only. Ballast dimmable from any incandescent dimmer. Other dimming ballasts available.

EMERGENCY BATTERY PACK: Remote mounted EBP, specify **REM**.

HANG HEIGHT: Standard overall hang height is 24" (ceiling to bottom of fixture). There is an additional charge for hang heights greater than standard. Minimum recommended is 18"

MOUNTING: Standard J-box or plaster ring.

WEIGHT: 6lbs

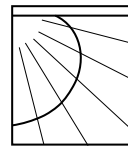

PHOTOMETRICS

Lighting Sciences Report 22542

Fixture Efficiency: 83.4%
Tested with metal shade.

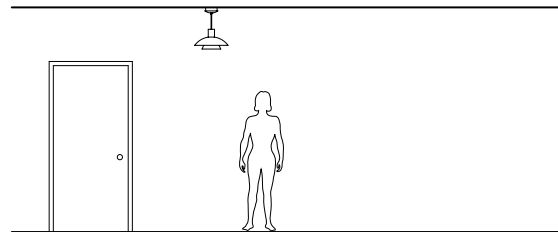

VARIATIONS / MODIFICATIONS

- Special finishes
- Addition of decorative detail
- Different shade size

SPEC GUIDE SAMPLE SPEC: 350-CF1/26-120-SAL-LS-FAUX-24"

CAT#	LAMPING	VOLT	FINISH	UPPER SHADE	OPTION	OA
<input type="checkbox"/> 350	<input type="checkbox"/> CF1/26 <input type="checkbox"/> CF1/32 <input type="checkbox"/> CF1/42	<input type="checkbox"/> 120 <input type="checkbox"/> 277 <input type="checkbox"/> 120DIM	<input type="checkbox"/> SAL <input type="checkbox"/> SB <input type="checkbox"/> AB <input type="checkbox"/> CCP	<input type="checkbox"/> LS <input type="checkbox"/> MS	<input type="checkbox"/> FAUX <input type="checkbox"/> REM <input type="checkbox"/> STEM	<input type="checkbox"/> 24" STD <input type="checkbox"/> SPECIFY

NOTE: Standard electronic ballast is multi-volt and multi-wattage. Fixture will accommodate 26, 32 or 42 watt lamps.

