

509

LUMINOUS SHIELD

ADA

Design
Sustainability
Value



print this page



email this page to a colleague



installation instructions



interactive submittal drawing

DESIGN: RANDY BORDEN



FEATURES

- ADA compliant.
- Clean classic design.
- Tool-free relamping.
- Available with perforated metal overlay.

ECO INFO

METALS: Sand cast mounting back is made from 100% recycled aluminum. Other aluminum and brass parts have the highest available recycled content for lower embodied energy and are valuable and recyclable at the end of the product's useful life. For more information see "GENERAL INFO"

FINISHING: Solid, natural metal finishes are sealed with a hand-applied bees wax. No paint or lacquer is used in order to avoid pollution associated with the manufacture and application of these substances. Clear coat finishes are available. Paint finishes are low VOC and oven cured.

ENERGY: Designed exclusively for compact fluorescent lamps using HPF electronic ballasts.

MATERIALS

- Solid aluminum or brass metal work, hand finished.
- Luminous shield is extruded white acrylic with a matte finish.

FINISHES

SAL Satin Aluminum

SB Satin Brass

MW Matte White

CCP Custom Color Painted finish

Standard metal finishes are hand satined and waxed. Low VOC lacquer available. Other metal finishes are available. Contact factory.

LAMPING

2-CF13TT, 2Gx7 base or 2-CF26W DTT, Gx24q base. Lamps not included.

BALLAST

Integral electronic HPF, 120V/277V. See "GENERAL INFO" for more detail.



Shown with Satin Aluminum Perforated Shield

509 ADA

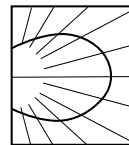
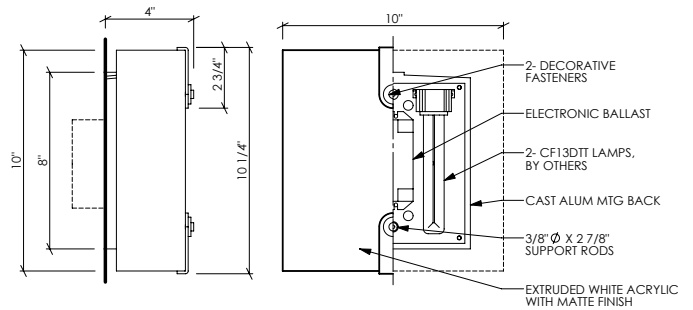

PHOTOMETRICS

Lighting Sciences Report No. 22748

Fixture efficiencies 71.6%

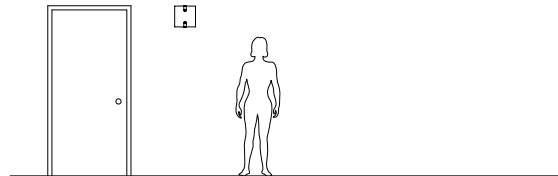

OPTIONS

FAUX: Hand applied faux finish available. Specify **FAUX**.

PERFORATED METAL SHIELD: Available with perforated metal shield as shown above. Specify **PERF**.

DIMMING: For 2-CF26W lamping only, available electronic ballast with a dimming range of 100-15%, 120 volt only. Ballast dimmable from any incandescent dimmer. Other dimming ballasts available.

EMERGENCY BATTERY PACK: Remote mounted EBP, specify **REM**.

VARIATIONS / MODIFICATIONS

- Special finishes
- Addition of decorative detail
- Custom laser cut patterned overlays

MOUNTING: Standard J-box or plaster ring.

WEIGHT: 4lbs

SPEC GUIDE SAMPLE SPEC: 509-CF2/13-120-SB-FAUX

| CAT# | LAMPING | VOLT | FINISH | OPTION |
|------------------------------|--|---|--|--|
| <input type="checkbox"/> 509 | <input type="checkbox"/> CF2/13 <input type="checkbox"/> CF2/26 | <input type="checkbox"/> 120 <input type="checkbox"/> 277 <input type="checkbox"/> 120DIM | <input type="checkbox"/> SAL <input type="checkbox"/> SB <input type="checkbox"/> MW <input type="checkbox"/> CCP | <input type="checkbox"/> FAUX <input type="checkbox"/> PERF <input type="checkbox"/> REM |



999 Montague St • San Leandro, CA 94577 • ph 510.357.0171 • fax 510.357.3832 • www.bordenlighting.com

